

VORTEX® VIPER® PST

PRECISION
SHOOTING
TACTICAL

SECOND FOCAL PLANE

EBR-1 MRAD Manual 6–24x50 Riflescope



Designed to maximize long distance shooting and

ranging abilities, the EBR-1 MRAD reticle can be used to effectively determine ranges, holdovers, windage corrections and moving target leads.

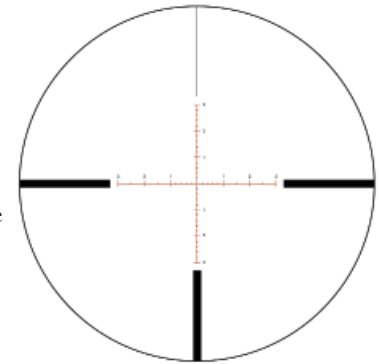

Ultra precision

laser etching on the glass reticle ensures that mrad specifications can be kept to the tightest tolerances possible. The fine center crosshair sub-tensions on the EBR-1 MRAD reticle were carefully chosen to provide the optimum balance between precision aiming and low light visibility.

MRAD Subtensions

The EBR-1 MRAD reticle is based on the milliradian, or mrad for short. Mrad unit of arc measurements are based on the radian. A radian is the angle subtended at the center of a circle by an arc that is equal in length to the radius of the circle. There are 6.283 radians in a circle and 1000 milliradians in a radian for a total of 6283 milliradians (mrads) in a circle. An mrad will subtend 3.6 inches at a distance of 100 yards. Most riflescopes using mrad adjustments will use .1 mrad clicks which subtend .36 inches at 100 yards.

Both mrad and MOA measurements are effective for ranging and bullet trajectory drop compensation in reticle designs. However, the mrad method used in the EBR-1 MRAD reticle has some important advantages over an MOA method. The primary benefit is that once learned, it is much simpler and faster to use. The mrad system will also be very easy for shooters familiar with the metric system and for those shooters with previous training in using mil dot reticles.

EBR-1 Reticle Subtensions

In this second focal plane riflescope, the listed mrad subtensions are *only* valid at the highest magnification of the scope. However, by understanding the relationship of magnification and subtensions, ranging, holdovers and wind drift can still be calculated at partial magnifications. If magnification is set at 1/2 of full magnification, subtension values will be two times the manual listed spec. If magnification is set at 1/3 full magnification, subtension values will be three times the manual

listed spec. If magnification is set at 1/4 of full magnification, subtension values will be four times the manual listed spec.

To help calculate range, holdover, wind drift at magnifications other than full power, the Viper PST 6–24x50 riflescope uses a dual number marking system on the magnification dial. The 1x, 2x, 3x, 4x subtension multiplier markings on the back side of the magnification numbers can be used in conjunction with the reticle to help calculate distances and holdovers at varying magnifications.

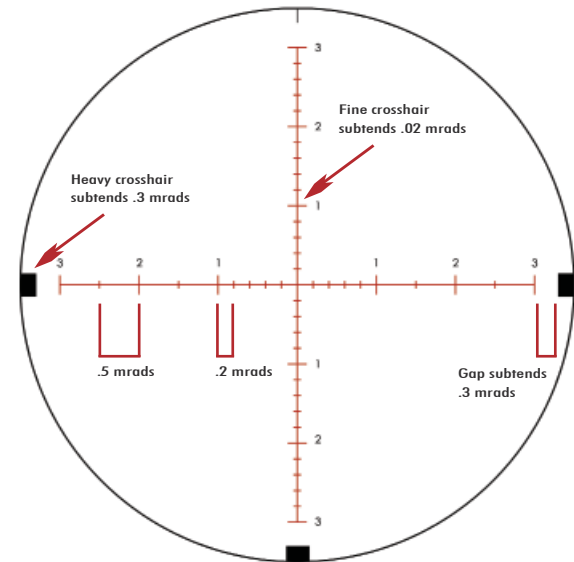

Subtension Changes with Magnification

Model	Riflescope Magnification	Reticle Multiplier	Actual Subtension of 1 mrad Reticle Space
6–24x50 Reticle subtensions valid at 24x	24x	1x	1 mrad
	12x	2x	2 mrads
	8x	3x	3 mrads
	6x	4x	4 mrads

Ranging

Mrad reticles such as the EBR-1 are very effective for ranging using simple formulas.

Mrad Ranging Formulas

$$\frac{\text{Target Size (Yards)} \times 1000}{\text{mrads Read}} = \text{Range (Yards)}$$

$$\frac{\text{Target Size (Meters)} \times 1000}{\text{mrads Read}} = \text{Range (Meters)}$$

$$\frac{\text{Target Size (Inches)} \times 27.8}{\text{mrads Read}} = \text{Range (Yards)}$$

To use these formulas, you will need to know the measured size of the target or a nearby object. Using either the vertical or horizontal mrad scale, place the reticle on the target of known measurement and read the number of mrads spanned.

Accurate measuring will depend on a very steady hold—the rifle should be solidly braced using a rest, bipod or sling. Once you have an accurate mrad reading, use any of the listed ranging formulas to calculate distance.

Maximum accuracy in ranging will be obtained by calculating exact mrad measurements—mrads should be estimated in tenths if possible.

Example

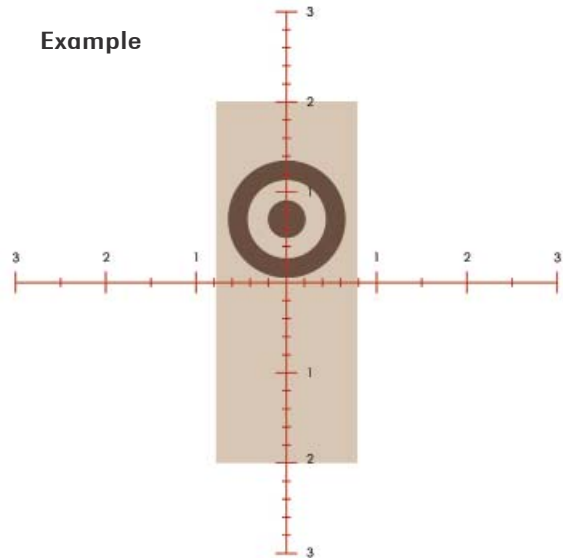

Ranging a 6-foot target (2 yards) at 4 mrads yields 500 yards.

$$\frac{2 \times 1000}{4 \text{ mrads}} = 500 \text{ Yards}$$

Elevation Holdovers

Once the distance has been calculated using the EBR-1 MRAD reticle or a laser rangefinder, the EBR-1 can be used for rapid holdover correction for bullet drop of the cartridge being used. To get the most benefit out of the EBR-1 equipped riflescope, Vortex Optics *highly* recommends shooters learn their bullet drop numbers in mrads rather than inches or MOAs. (Remember that 1 mrad equals 3.44 MOA or 3.6 inches per 100 yards).

Since the EBR-1 reticle is scaled in mrads, it is an easy job to quickly select the correct drop reference line once the shooter knows their bullet drops and windage/lead corrections in mrads. If the shooter prefers to dial *come ups* for bullet drop using the elevation knob, knowing bullet drops in mrads will allow for much faster adjustments as the mrads can be quickly read on the elevation knob.

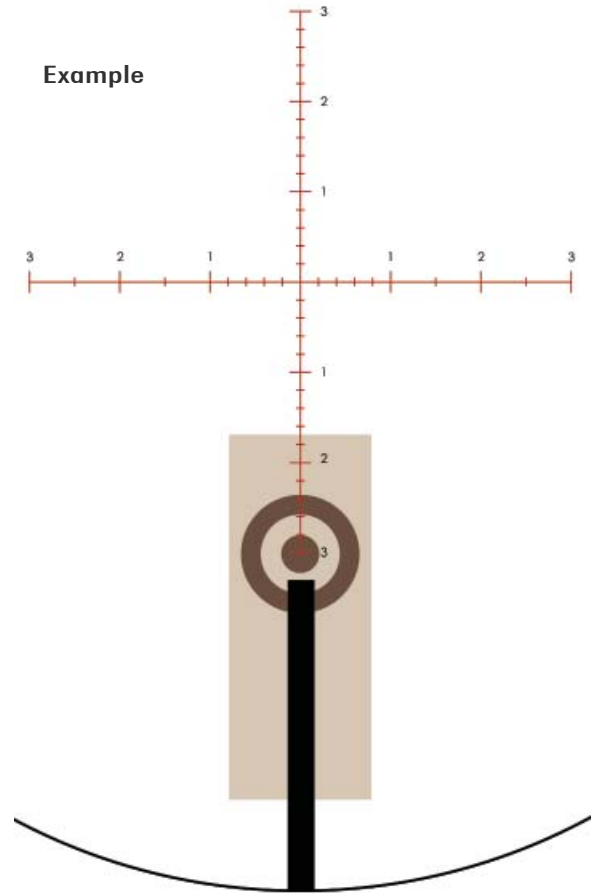

3 mrad correction for 500-yard shot. No wind.

Windage and Moving Targets

The EBR-1 reticle is highly effective when used for wind and moving target leads.

Using the reticle for effective windage and moving leads will require thorough knowledge of your weapon system's ballistic performance under varying conditions and experience in reading wind strengths and target speeds. As in bullet drops, it is imperative the shooter learn the particular weapon's windage/moving target corrections in mrads rather than inches or MOAs.

Basic windage correction on center crosshair

When dialing elevation *come ups*, the center horizontal crosshair will be used for windage or moving lead corrections.

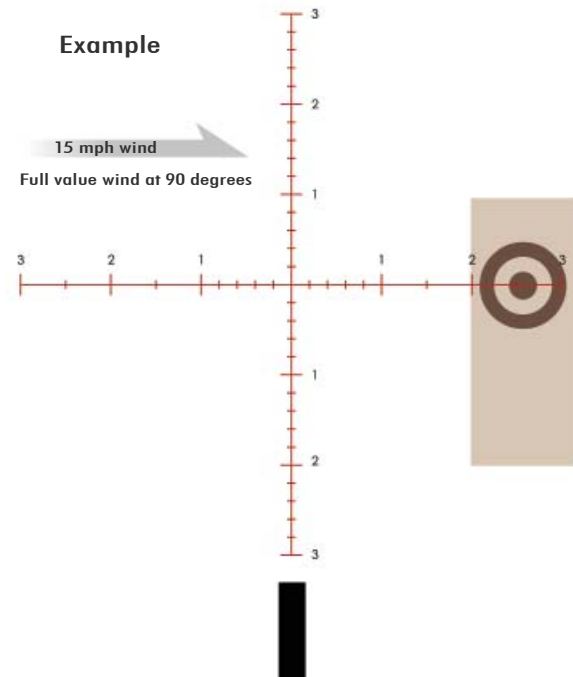

2.6 mrad correction for 15 mph wind at 700 yards.

Elevation already dialed into turret.

Basic windage correction using drop line on reticle

When using the reticle for elevation correction rather than dialing, the mrad marks on the center horizontal crosshair can still be used to help visually reference windage corrections. Remember to hold the reticle into the wind.

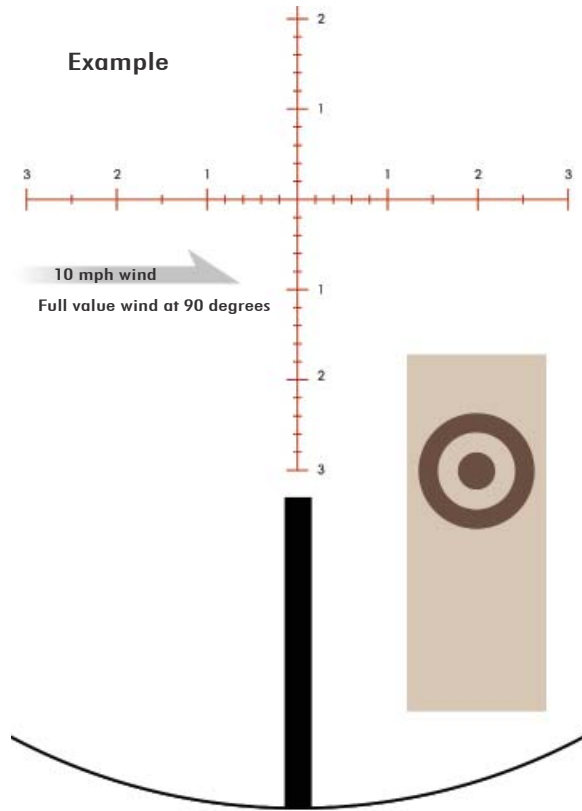

Using 3 mrad drop line at 500 yards, 2 mrad correction for 10 mph wind.

Basic moving lead correction

When estimating moving target leads, the mrad marks on the center horizontal crosshair and can be used. Estimating moving leads will require knowing yardage distance, wind speed, moving target speed and total bullet flight times including rifle lock time. Bullet flight times can be roughly calculated based on fps velocities or a ballistic calculator.

Note: Correctly estimating moving leads is very difficult and requires considerable practice and knowledge beyond the scope of this manual.

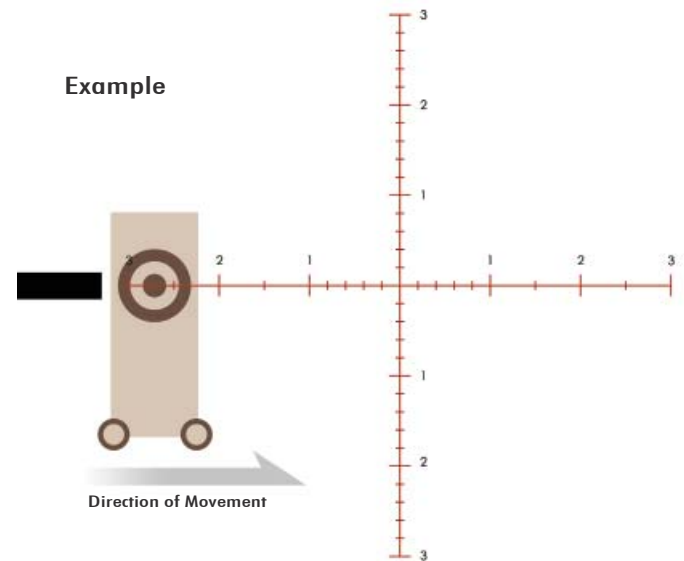

2.74 mrad correction for a target moving at 3 mph at 800 yards. No wind.
Total bullet time of flight from trigger pull 1.5 seconds during which target travels 6.6 feet. Elevation already dialed into turret.



Vortex Service and Repair Policy

Unconditional Lifetime Warranty

Vortex Optics wants you to shoot and use your Viper PST rifle scope under any conditions with complete confidence—that's why our warranty is straightforward and simple:

- Fully transferable
- No warranty card needed
- No receipt needed

Rest assured, if this rifle scope should ever require repair, all you need to do is contact Vortex for absolutely free service. Call 800-426-0048 or e-mail service@vortexoptics.com.

Vortex Optics
2120 West Greenview Drive
Middleton, Wisconsin 53562
USA

Patent Pending
Dual Use: Shooting Tactical / Hunting



Unconditional Lifetime Warranty



Dual Use: Shooting Tactical / Hunting

Manual #R-624S1-M2